

LOC	DIST	REVISIONS					
E	B	P	LTR	DESCRIPTION	DATE	DWN	APVD
		F		EBD0-0463-04	08DEC04	RS	MG

NOTES:

- △ FOR STRIP VERSION SEE DWG. 164153.
- △ UNDERCOATING: 1,3µm Ni.
SELECTIVE : 0,8µm Au.
ZONE I : BRIGHT TIN PLATED.
- △ UNDERCOATING: 1,3µm Ni.
SELECTIVE : 0,8µm Au.
REMAINDER : GOLDFLASH.

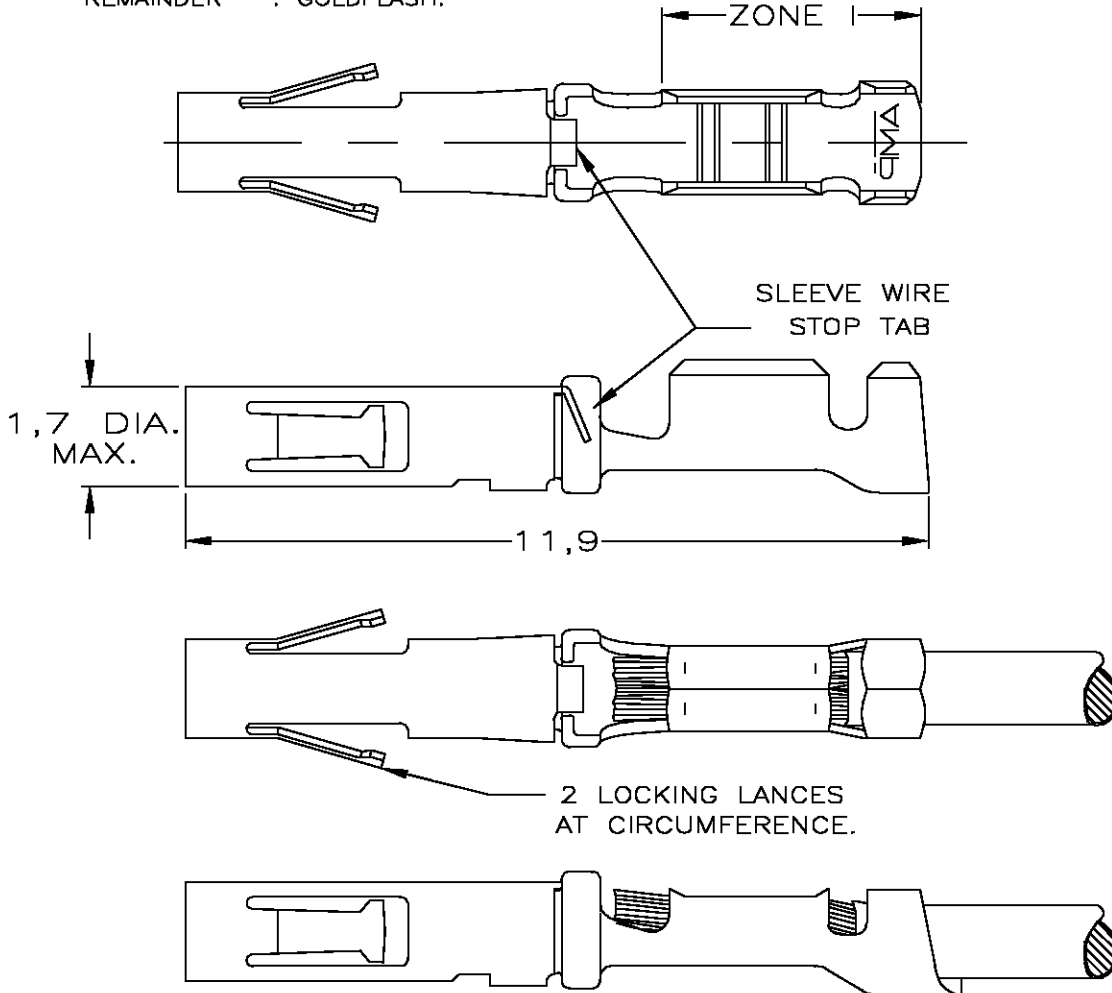

WIRE RANGE :
24-20 AWG 0,20-0,56 mm²
INSULATION RANGE :
1,57 DIA. MAX.

STAINLESS STEEL	SEE NOTE 2	BRASS	164169-4
	PRETINNED		164169-3
	POST TINPLATED		164169-2
	SEE NOTE 3		164169-1
MATERIAL OF SLEEVE	PLATING OF BODY	MATERIAL OF BODY	PARTNUMBER

RELEASED FOR PUBLICATION JAN , 1993.

ALL RIGHTS RESERVED.

COPYRIGHT 1993 BY TYCO ELECTRONICS CORPORATION.

THIS DRAWING IS UNPUBLISHED.

DIMENSIONS: mm	DWN J.v.LIEMPT 6 JAN 1993	MATERIAL	FINISH
	CHK C.v.TILBURG 08-02-93	Tyco Electronics Corporation Bideford, UK, EX39 4HE	
TOLERANCES UNLESS OTHERWISE SPECIFIED:	APVD L.v.SOEST 08-02-93	NAME HDR SOCKET CONTACT TYPE XI (CRIMP SNAP-IN) L.P.	
	PRODUCT SPEC	SIZE	CAGE CODE
0 PLC ± -	APPLICATION SPEC	DRAWING NO	RESTRICTED TO
1 PLC ± -	WEIGHT	A4 00779	C-164169
2 PLC ± -	CUSTOMER DRAWING	SCALE	SHEET 1 OF 1
3 PLC ± -		REV	F
4 PLC ± -			
ANGLES ± -			